

OASYS OLA RANGE OF LAMINATING SYSTEMS



OLA LAMINATORS

- Proven track record for high quality lamination
- Enhanced specifically for the lamination of high quality contactless products
- Rigid four pillar construction
- Thermally efficient lightweight alloy platens
- Self diagnostic touch screen control system
- Two stage hydraulic pump control
- 4 cylinder hydraulic force application
- Ramped heating and cooling facility
- Optional semi automatic cassette load/unload facility
- Optional fully automatic cassette load/unload facility
- Optional modem link facility
- Optional tilt table cassette loading

Ola 2-3 LAMINATOR (STANDARD MANUAL FEED PRESENTATION)



Ola 1-4 LAMINATOR WITH SEMI AUTO FEED STATION AND TILT TABLE



Touch screen



4 cylinders

Specifications

General: Safety: All Oasys machines are CE certified and comply with relevant European safety requirements including emergency stops and interlocked guarding.

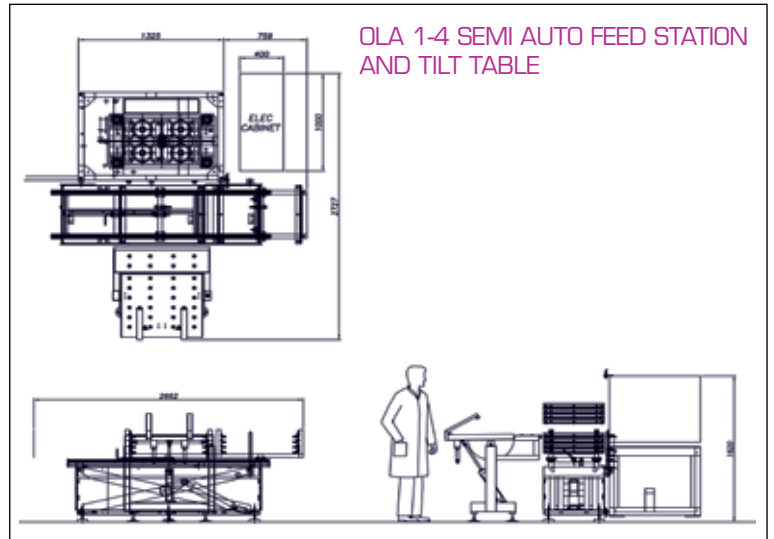
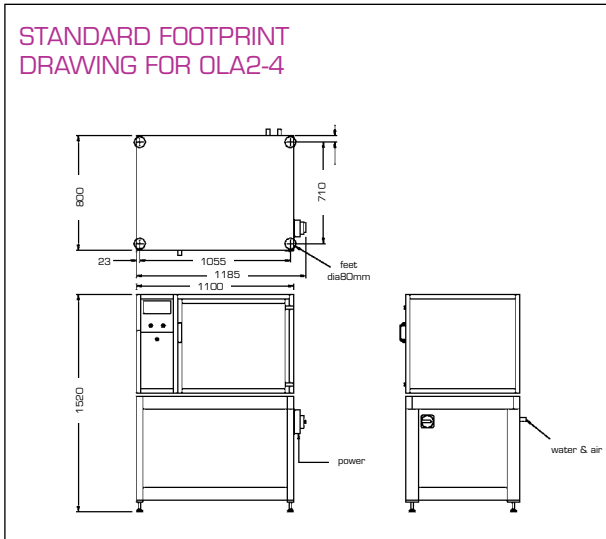

TYPICAL SPECIFICATIONS FOR THE OLA RANGE WITH 4 OPENING CONFIGURATION:

OLA1-4

- Output up to 1600 cards/cycle
- Max. Lamination area: 685x490 mm
- Electrical: 400V +/- 5%, 50 or 60Hz, 3 Ph, 60 KVA
- Pneumatics: 100 litres/min @ 5.5 bar (3.5 CFM @ 80 psi)
- Machine Weight (packed): Packed 2630 kgs
- Total Shipping Dimensions (1 crate): L1800 x W1250 x H1930 mm

OLA2-4

- Output up to 1280 cards/cycle
- Max. Lamination area: 514x415 mm
- Electrical: 400V +/- 5%, 50 or 60Hz, 3 Ph, 44 KVA
- Pneumatics: 100 litres/min @ 5.5 bar (3.5 CFM @ 80 psi)
- Machine Weight (packed): Packed 1290 kgs
- Total Shipping Dimensions (1 crate): L1540 x W1130 x H1840 mm

OLA3-4

- Output up to 720 cards/cycle
- Max. Lamination area: 403x318 mm
- Electrical: 400V +/- 5%, 50 or 60Hz, 3 Ph, 34 KVA
- Pneumatics: 100 litres/min @ 5.5 bar (3.5 CFM @ 80 psi)
- Machine Weight (packed): Packed 980 kgs
- Total Shipping Dimensions (1 crate): L1450 x W1050 x H1840 mm

Note: OLA series available with either 3, 4 or 6 openings.

- * Specifications are subject to change without notification.
- * Actual output rates will be dependent upon product used, settings and configurations.

For further information:
 OASYS TECHNOLOGIES LTD, Jubilee Trade Centre, Letchworth Garden City, Herts, SG6 1SP, England
 Tel: +44 1462 480933 Fax: +44 1462 480292 E-mail: sales@oasys.uk.com Web Site: www.oasys.uk.com